



**REVERSOMATIC**  
MANUFACTURING LIMITED

## 3-Stage, Whole-house Filtration System

**HEPA Air Cleaner**  
RAC-200/400

*Breathe easier...  
Breathe clean,  
healthy air.*



Reversomatic Manufacturing Limited certifies that the RAC-200 shown herein is licensed to bear the AMCA Seal. The ratings are based on tests and procedures performed in accordance with AMCA publication 211 and AMCA publication 311 and comply with the requirements of the AMCA Certified Ratings Program.

### *You filter your drinking water...why wouldn't you filter the air you breathe?*

Our 3-stage HEPA filtration system removes dust, dirt, allergens and pollutants that can cause respiratory illness (particularly in young children and seniors) :

Removes 99.97% of allergens and spores.



- asthma
- common cold and flu
- other health issues that may show up later in life



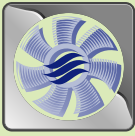

## 3-Stage, Whole-house Filtration System

RAC-200/400



## Features and Benefits:

- Pleated pre-filter captures larger particles.
- Activated carbon filter removes household odors, e.g. cooking, pets, household chemicals, smoke and VOCs.
- HEPA media filter - 99.97% effective. Captures much smaller particulate down to 0.3  $\mu$  including mold spores, fungi, bacteria, viruses and more.
- Insulated cabinet reduces noise.
- Variable speed switch controls motor speed.
- Can be installed duct mounted, wall hung, collar mounted or free standing. Comes with duct and collar knock outs.
- Hassel-free front panel allows for easy access to change filters.
- Powder-coated paint.
- Strong, durable steel construction.

## Optional Accessories:

- Replacement Filter – HEPA Filter (Part # 500007)  
15 - 3/4" x 11 - 1/2" x 2"
- Pleated Pre Filter with activated carbon (part #500008) 15 - 3/4" x 11 - 1/2" x 2"
- Polypropylene caster wheels (for portable unit) (part #500009)

## INSTALLATION OPTIONS

### Portable Free Standing

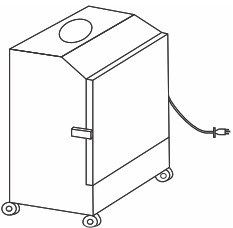

### Duct Mounted

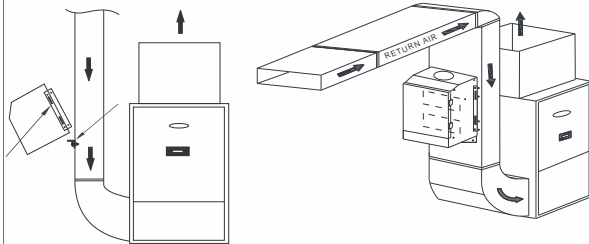

### Collar Mounted

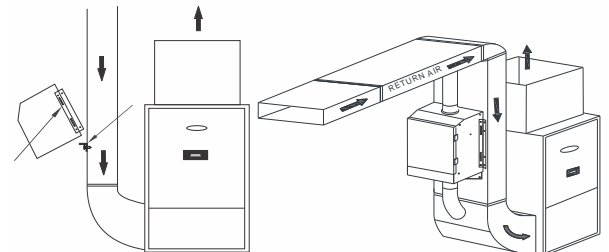

## UNIT DIMENSIONS

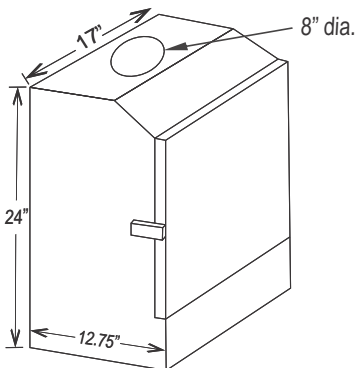

### RAC-200/400

Height 24"  
Width 17"  
Depth 12.75"

## PERFORMANCE

- RAC-200: **227CFM** @ 0 in. W.C. (max. speed) / **2.8 Sones** (operating speed)
- RAC-400: **380CFM** @ 0 in. W.C. (max. speed) / **3.5 Sones** (operating speed)
- Powerful PSC motor with permanently lubricated ball bearings for long life and vibration-free operation.
- Pre-wired 9' - 10' long cord with three prong plug.
- Voltage: 115V/1/60HZ
- Power consumption: RAC-200: **105 W** (max. speed)  
RAC-400: **300 W** (max. speed)
- Weight (approx.): RAC-200: **30.5 lbs**; RAC-400: **35.0 lbs**

### Important Notes:

- Performance ratings include the effect of pre/carbon filter and HEPA filter.
- Performance certified is for installation type B - Free inlet / ducted outlet.
- Speed (RPM) shown is nominal.
- Air performance is for speed at 2600 nominal RPM. Performance is based on actual speed of test.
- Test was conducted at standard air conditions.



Reversomatic Manufacturing Ltd.

790 Rowntree Dairy Road, Woodbridge, ON Canada L4L 5V3 • Tel: 905-851-6701 • Fax: 905-851-8376  
www.reversomatic.com • info@reversomatic.com